

ZAHNER

PRECISION IN ELECTROCHEMISTRY



FRA-X

INTERFACE FOR HIGH-POWER EIS

FRA-X - Made in Germany



Main Specifications

- Current ranges: ± 500 A, ± 1000 A, ± 2000 A, ± 4000 A, or ± 6000 A
- Voltage ranges: ± 5 V, ± 70 V, ± 140 V, ± 700 V, or ± 1400 V
- Control voltage range for analog interface: ± 10 V
- EIS frequency range*: 10 μ Hz to 100 kHz
- Up to 33 true parallel measurements on a stack
- Remote integration possible via C++, Python or WebSockets

* Impedance frequency range defined for the FRA-X

” INTERFACE FOR HIGH-POWER EIS “

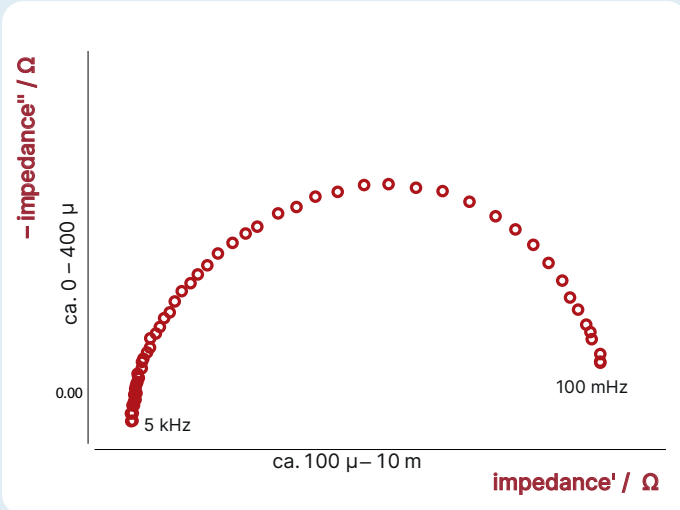

Impedance spectrum measured on industrial-scale **PEM electrolyzer cell** using an FRA-X interface and a Regatron power supply.

Connection Scheme

- Sine signal for EIS is regulated by a IM7 series potentiostat via an FRA-X interface
- Output current is sourced/sunk by an external power supply/load
- Input current and voltage are directly monitored by the FRA-X via transducers
- Current and voltage recording is galvanically isolated from the external power supply/load
- In-phase current/voltage recording by FRA-X enables high-precision EIS

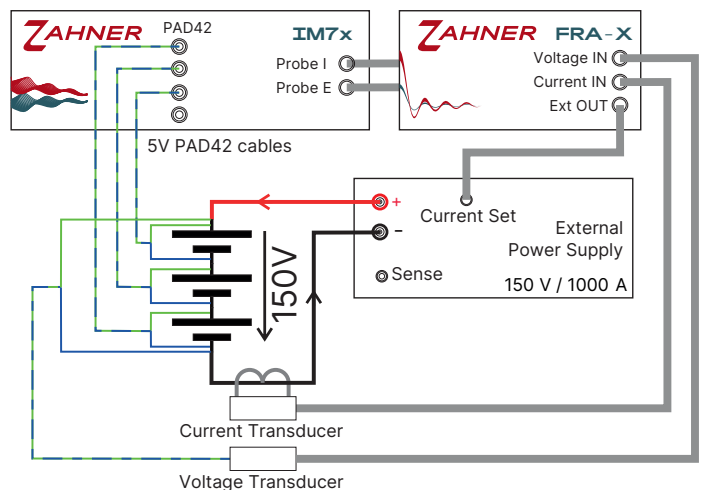

Connection scheme among a IM7 series potentiostat, a FRA-X, a third-party power supply, and a test object.



Check out the QR code for useful examples and complete API documentation.



Zahner-Elektrik GmbH & Co. KG
 contact@zahner.de
 www.zahner.de